

LOC		DIST		REVISIONS			
P	LTR	DESCRIPTION	DATE	BY	APPD		
P		REVISED PER 063B-1094-04	24JAN85	KW	SR		

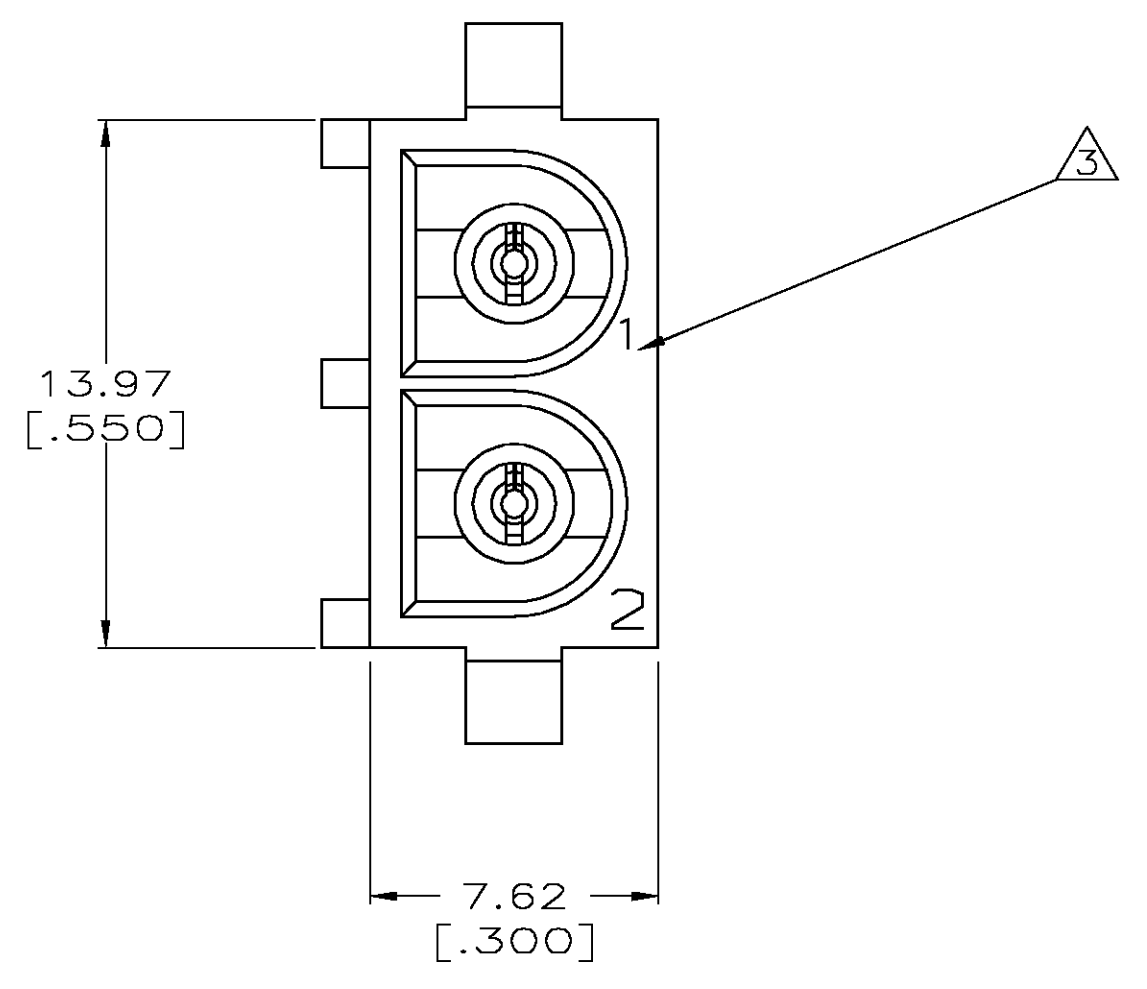

- PARTS COMPLY TO AMP SOLDERABILITY SPECIFICATION 109-11-3.
- CONTACT IS PLATED OVERALL WITH 0.00127 [.000050] NICKEL, THEN 0.00076 [.000030] GOLD OVER CONTACT LENGTH INDICATED AND MATTE TIN LEAD ON SOLDER TAIL END.
- CIRCUIT IDENTIFICATION CHARACTERS ARE ADJACENT TO THE INDICATED CAVITIES, BUT LOCATION AND ORIENTATION MAY DIFFER FROM PRINT.
- DIMENSIONS IN BRACKETS ARE IN INCHES.
- CONTACT IS PLATED OVERALL WITH 0.00127 [.000050] NICKEL, THEN 0.00076 [.000030] GOLD OVER CONTACT LENGTH INDICATED AND MATTE TIN ON SOLDER TAIL END.

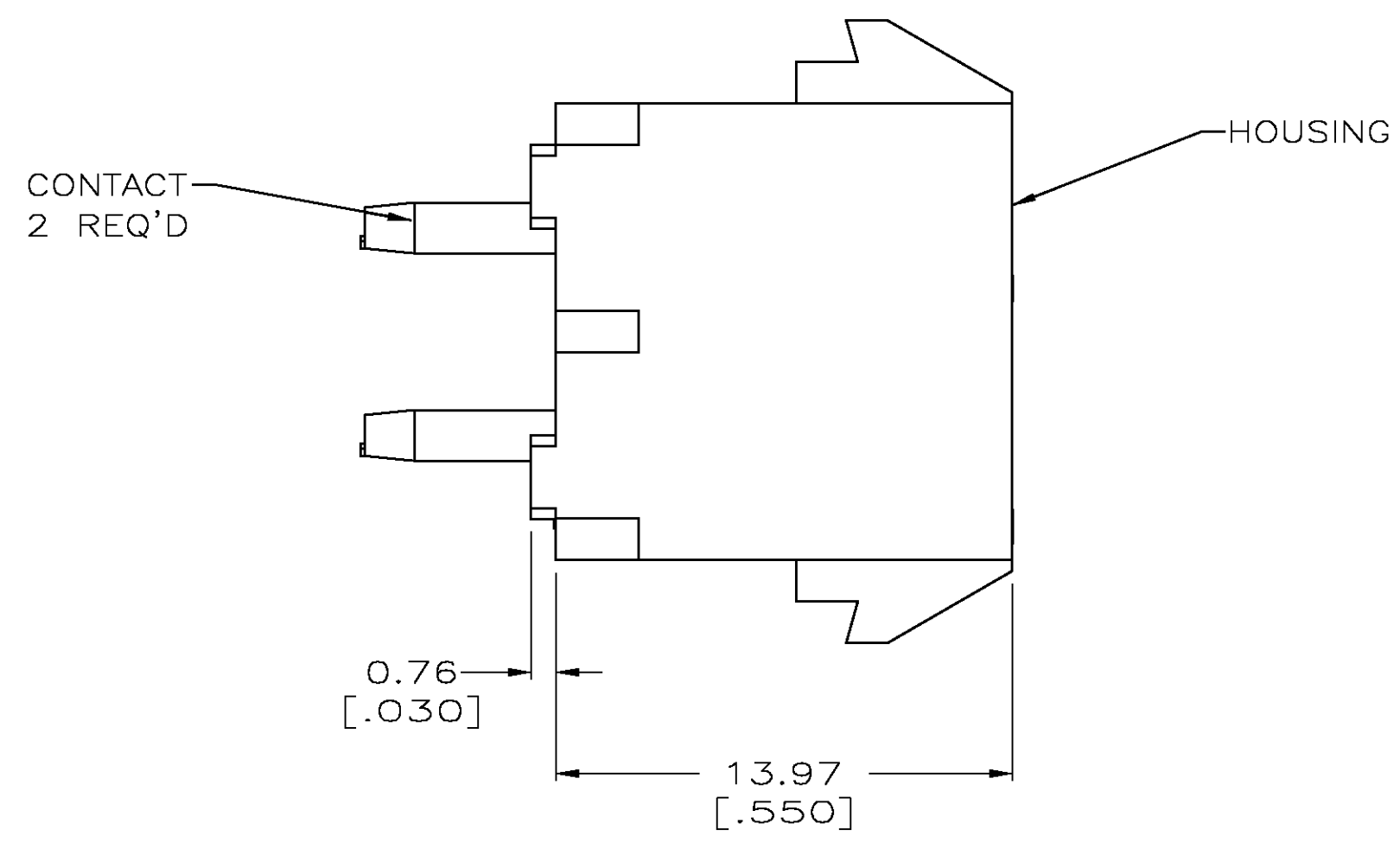
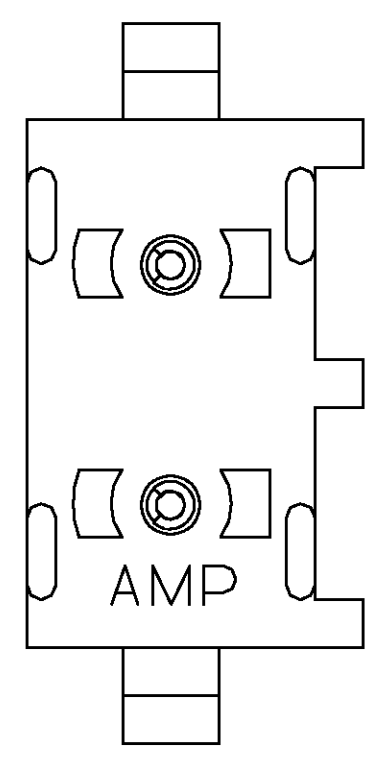
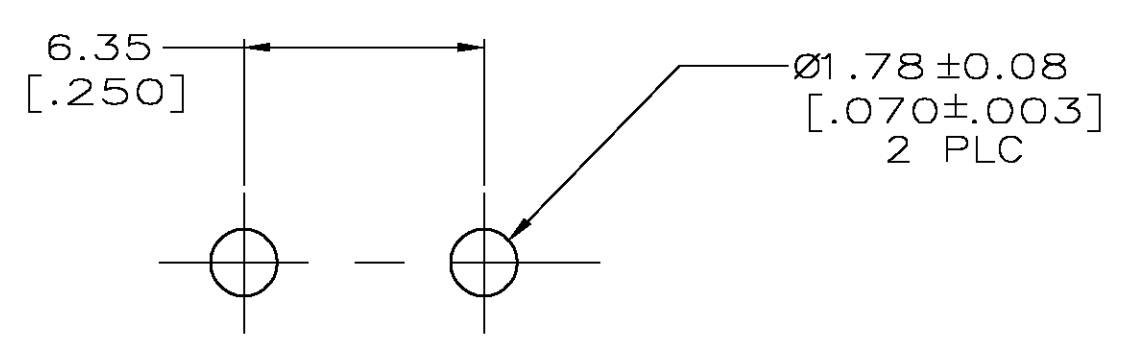
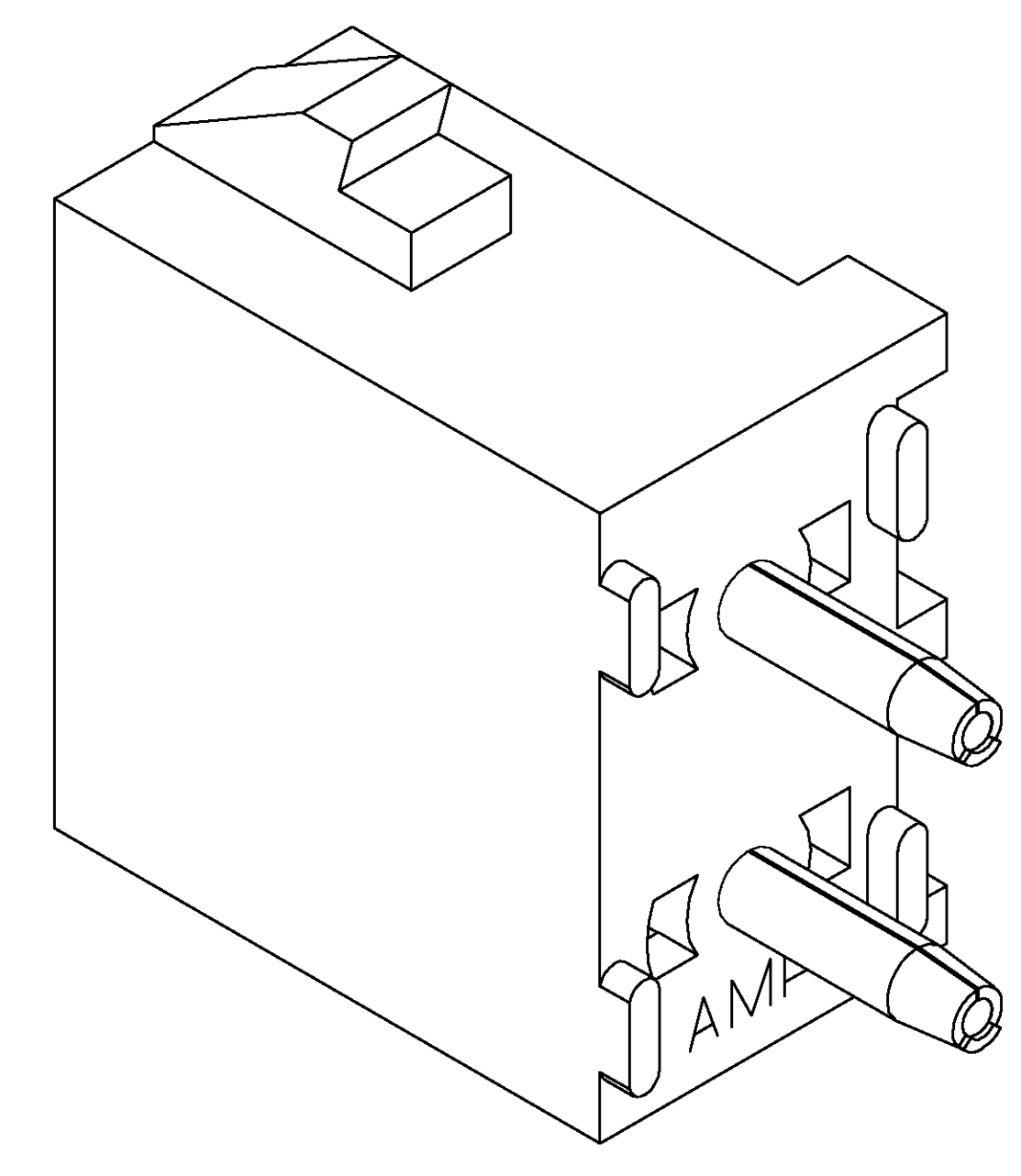
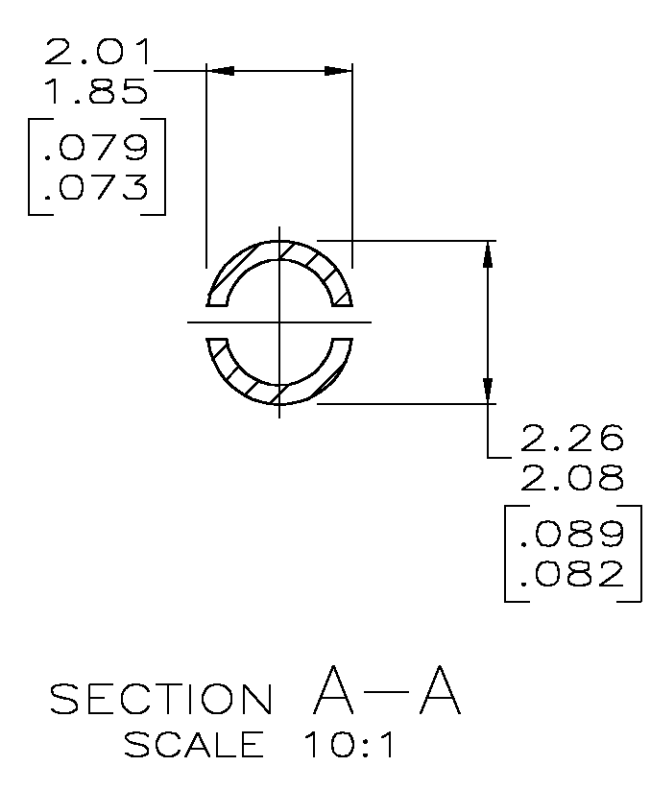
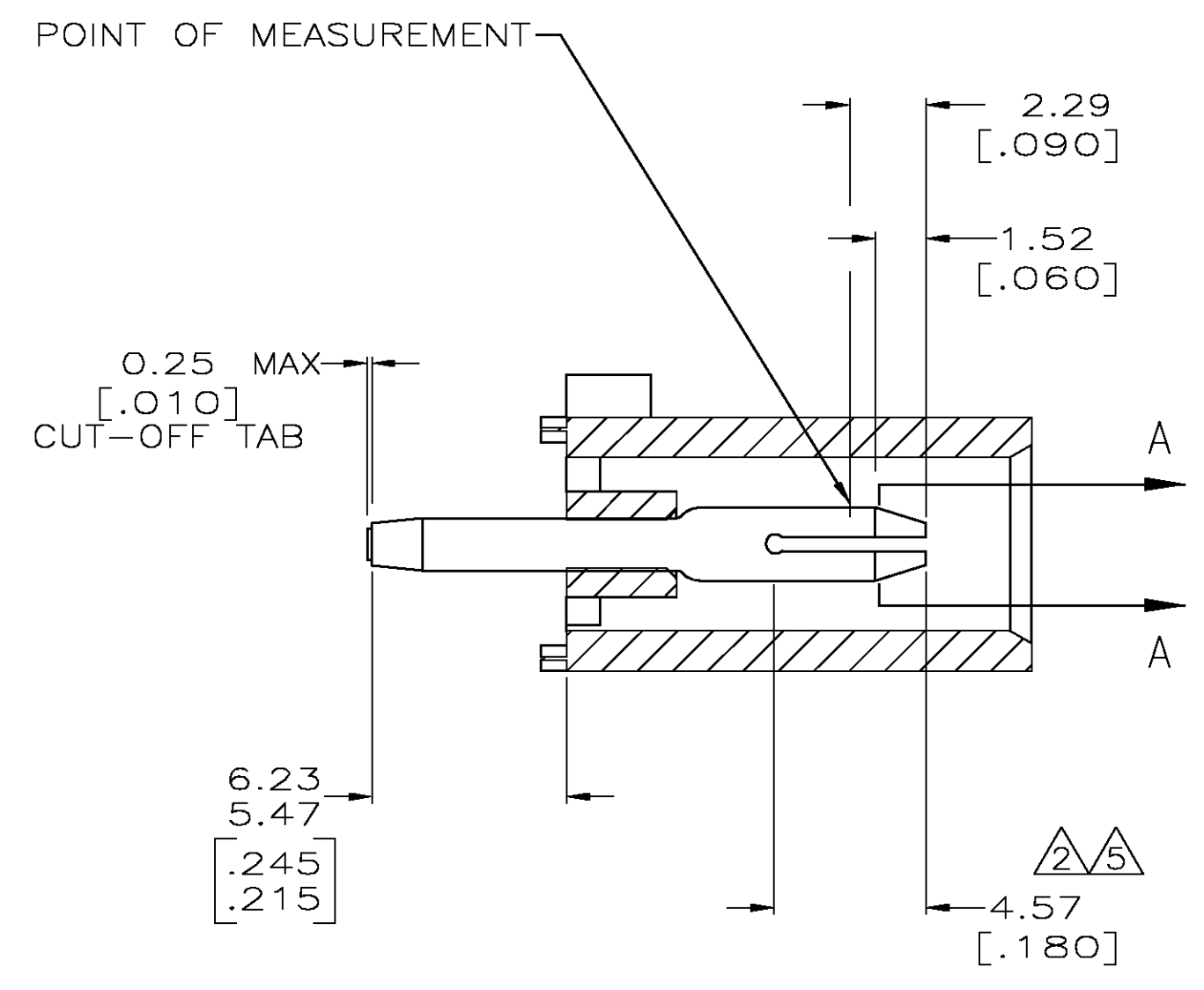

RECOMMENDED MOUNTING HOLE PATTERN FOR 3.18 [.125] THICK P.C. BOARD

PHOSPHOR BRONZE, GOLD	NYLON, UL94V-0, WHITE	350787-3
PHOSPHOR BRONZE, GOLD	NYLON, UL94V-0, WHITE	350787-2
PHOSPHOR BRONZE, PRE-TIN	NYLON, UL94V-0, WHITE	350787-1
PIN CONTACT MATERIAL AND FINISH	HOUSING MATERIAL	PART NUMBER

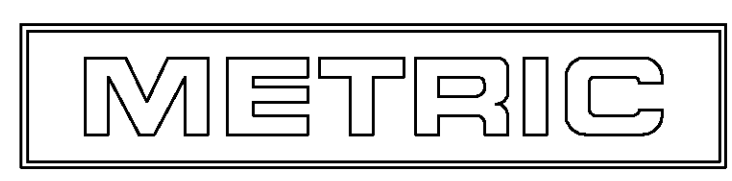

THIS DRAWING IS A CONTROLLED DOCUMENT.

DIMENSIONS: mm [INCHES]	TOLERANCES UNLESS OTHERWISE SPECIFIED: 0 PLC ± - 1 PLC ± - 2 PLC ± 0.13 [.005] 3 PLC ± - 4 PLC ± - ANGLES ± - 0° 30'	FINISH SEE TABLE	DWG BY: LEWIS 8-20-98 CHK R. SWING 8-20-98 APVD M. TRULL 8-20-98 NAME: PIN HEADER ASSEMBLY, 2 CIRCUIT UNIVERSAL MATE-N-LOK™ SIZE: A1 CAGE CODE: 00779 DRAWING NO: 350787 WEIGHT: - CUSTOMER DRAWING	Tyco Electronics Corporation Greensboro, NC 27409 RESTRICTED TO: - SCALE: 5:1 SHEET: 1 of 1 REV: P
----------------------------	--	---------------------	---	---